

Product Group: Spouts
 Sub Group: PSP009 Series ¹
 Item: Outside Spout

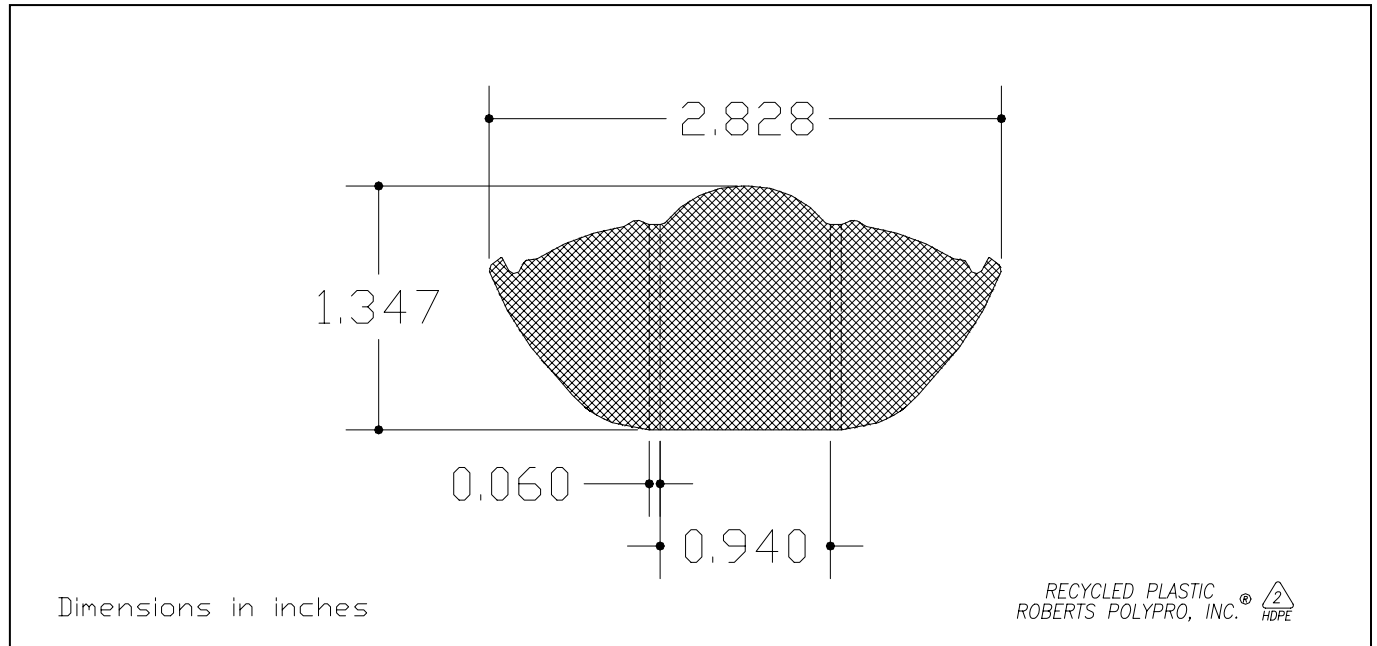

Current Product Numbers

PSP009C.BLK.A Welded, Black Outside Pour Spout
PSP009C.WHT.A Welded, White Outside Pour Spout
PSP009C.NAT.A Welded, Natural Outside Pour Spout
PSP009C.113.A Welded, Yellow Outside Pour Spout
Custom Ask us about customizing a product to meet your specifications

Quality Specifications

Material: High Density Polyethylene
Thickness: 0.032" ± 0.001"
Flatness Gauge: 1 Part Thickness
Surface Finish: Gloss
Part Weight: 1.280 grams
Cartridge Count: 160 ²
Cartridge Weight: 0.4515 ²
Weld Strength: 4 lbs. ± 1 lb. ²
Weld Test Frequency: 1 Stick per Cavity - Every 10 Cases ²

Packaging Information

| | | |
|--------------------------|-----------------------------|--|
| Case Quantity: | <i>Loose:</i> Not Available | <i>Welded:</i> 13,440 |
| Case Dimensions: | <i>Loose:</i> Not Available | <i>Welded:</i> 15.625" x 11.625" x 9.6875" |
| Pads per Case: | <i>Loose:</i> Not Available | <i>Welded:</i> 4 |
| Pad Dimensions: | <i>Loose:</i> Not Available | <i>Welded:</i> 15.5" x 11.4375" |
| Case Weight: | <i>Loose:</i> Not Available | <i>Welded:</i> 39.9 lbs. |
| Pallet Weight: | <i>Loose:</i> Not Available | <i>Welded:</i> 1237 lbs. |
| Cases per Pallet: | <i>Loose:</i> Not Available | <i>Welded:</i> 30 |

Packaging Notes: *Loose* - Not Available *Welded* - A 16P2 pad is placed on the bottom of a 16C2 case, followed by 4 layers of 21 sticks or 13,440 parts per case minimum. Each layer consists of 4 rows of 3 sticks flat side down on bottom with 3 rows of 3 sticks flat side up on top. Each layer is separated by a 16P2 pad. Another 16P2 pad is placed on top and the box is tape sealed.

¹ This spout is an exclusive, patented Roberts PolyPro design.
² Applies only to welded spouts.